

STRAIGHT PLUG, CRIMPED TYPE
FOR CABLE 6/75

PEN 90-0400-318

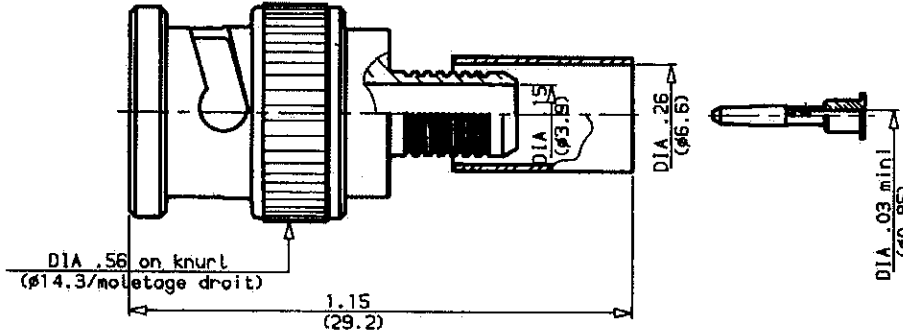

WEIGHT: 3.5 oz (9.8g)

cables: MARSHALL 8450

CHARACTERISTICS

NOMINAL IMPEDANCE	75 Ω
FREQUENCY RANGE	0-1.5 GHz
TEMPERATURE RATING	-35/+70 °C
VSWR	NA Max
RF INSERTION LOSS	NA \sqrt{f} dB Maxi
VOLTAGE RATING	500 Vrms Maxi
DIELECTRIC WITHSTANDING VOLTAGE	1500 Vrms mini
INSULATION RESISTANCE	5000 M Ω mini
HERMETIC SEAL	NA cc/s Atm.cm ³ /s
LEAKAGE (pressurized only)	NA psi MPa
-	-
-	-

STANDARDISATION

CABLE RETENTION	AD	lb mini
CENTER CONTACT RETENTION		N
Axial force - mating end	2.25	lb mini
Axial force - opposite end	2.25	lb mini
Torque (Min)	NA	Inch.oz cm.N
RECOMMENDED TORQUES		
Mating	NA	Inch. lb cm.N
Panel nut	NA	Inch. lb cm.N
Clamp nut	NA	Inch. lb cm.N

CONSTRUCTION

CONNECTOR PARTS	MATERIALS	FINISH
BODY	BRASS	NICKEL
OUTER CONTACT	BRASS	NICKEL
CENTER CONTACT	BRASS	GOLD
INSULATORS	POLYPROPYLENE	-
-	-	-
-	-	-
-	-	-
-	-	-
-	-	-

ISSUE	REVISION No	DESCRIPTION	BY	DATE
D00	DM 08-01-009	White polypropylene -> polypropylene	TRIPER	18/02/08

Initiated on 26-JUN-90

The information given here is subject to change without notice. Design changes may be in order to improve the product.



Superseded on



CABLE 6/75 STRAIGHT PLUG CRIMPED TYPE

SERIES: BNC 75Ω

02/02

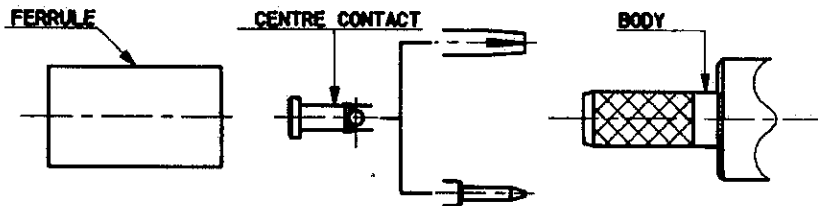

①
1-1 Slide onto the cable the ferrule

1-2 Strip the cable .

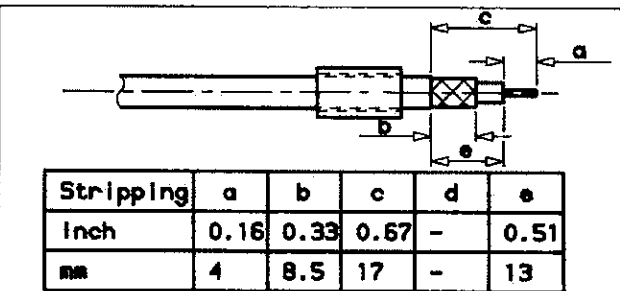

②
2-1 Slide on the centre contact until it bottoms against cable dielectric .
2-2 Crimp centre contact , crimping tool R 282 223 000 (Hex. 1.07) or crimping tool M22520/5-01 + dies M22520/5-13

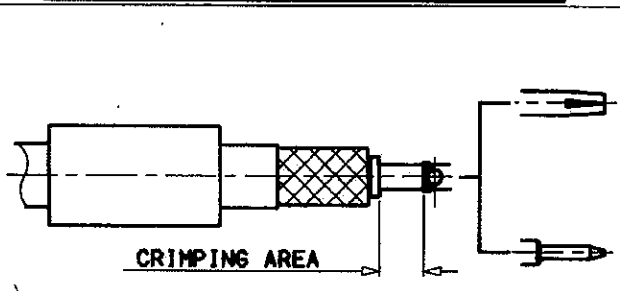

③
3-1 Fan the braid .
3-2 Slide cable into the body until bottoms against insulator .
3-3 Slide ferrule over the braid (in direction F)

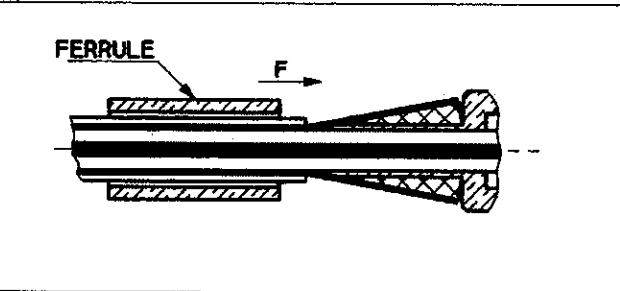

④
4-1 Crimp the ferrule with crimping tool R 282 223 000 (Hex. 1.255) or Crimping tool M22520/5-01 + dies M22520/5-13
4-2 Cut the excess of braid .

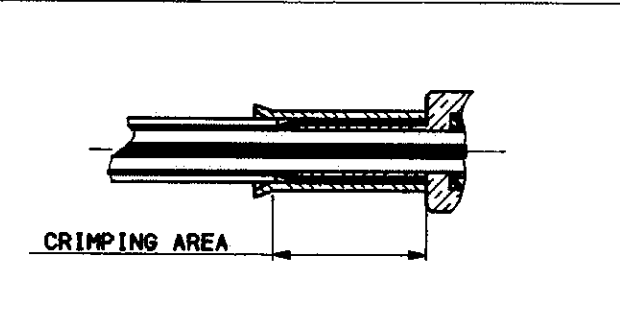

ISSUE	REVISION No	DESCRIPTION	BY	DATE

Initiated on 27 Jun 90
Superseded on _____

The information given here is subject to change without notice. Design changes may be in order to improve the product.

